

Summer Semester 2015

Software Engineering Design & Construction

Dr. Michael Eichberg
Fachgebiet Softwaretechnik
Technische Universität Darmstadt

Visitor Pattern

Visitor Design Pattern

The Visitor Pattern enables **to add new behavior** to existing classes in a fixed class hierarchy without changing this hierarchy.

Intent of the Visitor in Context

Recall the problems of inheritance with modeling variations at the level of multiple objects (object composites).

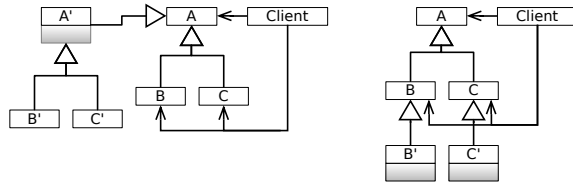

3

Problems:

- Weak support for combining variations at the level of the composite with those at the level of individual elements.
- No support for expressing **covariant variations**.
- Instantiation problems.

Solution Idea

Represent the additional operations to be performed on the elements of an object structure (additional features) as objects (of type Visitor).

4

Structure

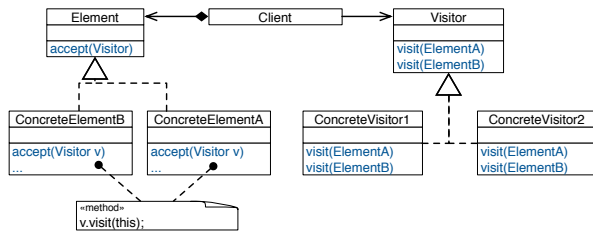

```

Element e = new ConcreteElementA(...);
Visitor v = new ConcreteVisitor1(...);
e.accept(v);
    
```

The Visitor interface declares a visit method per element type in the object structure.

A Visitor interface describes how to “treat” the element types.

Concrete visitor classes implement the interface specifically, i.e., treat elements differently.

A concrete visitor class corresponds to a particular feature to be added to the object structure.

Elements in the object structure provide the method accept(Visitor).

On being asked to accept a visitor passed to it as a parameter, an element asks the visitor to visit it.

Structure

(Long Version)

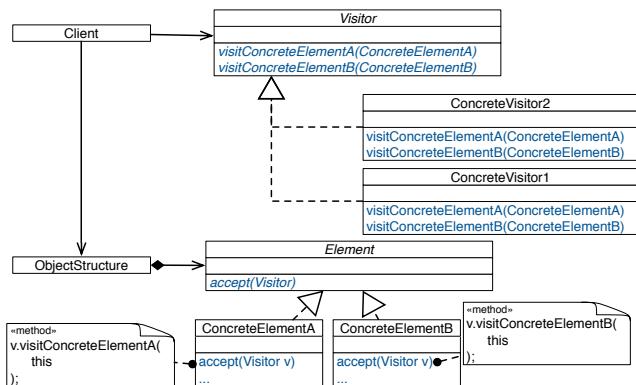

Case-Study: Arithmetic Expressions

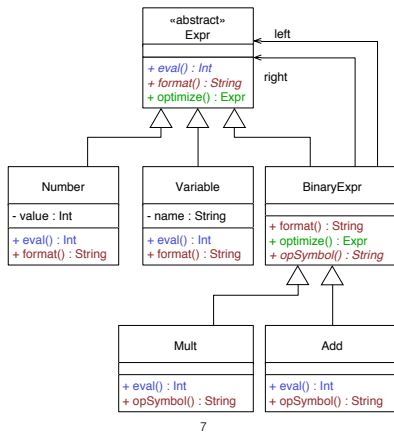

7

Requirements

- A library for (arithmetic) expressions must provide different functionality for:
 - Formatting an expression to a string.
 - Computing the value of an expression.
 - Optimizing an expression.
- The library must be extensible with new functionality:
 - Generate code for different machines,
 - Various refactorings, e.g., rename variables,
- The library must be extensible with new kinds of expressions.

Which are the potential design issues?

Design Issues:

- Impossible to reuse part of library functionality (product lines).
- Changing one feature can destabilize other features (SRP).
- New features cannot be incrementally added (OCP).

Visitor Based Design

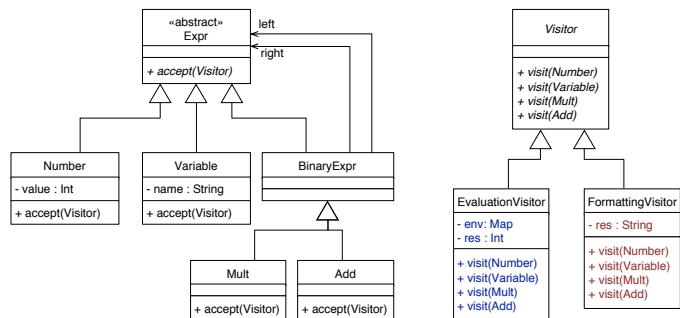

8

The dispatch of the operations defined in the Element hierarchy depends on two parameters:

1. Dynamic type of the receiver Element determines the class that has the needed method look-up table.
2. Name of the operation being called determines the entry in that table.

For operations that are outsourced to visitors, we need to simulate the same dispatch semantics.

We need to select an implementation of an operation based on both

1. the dynamic type of the element on which to apply the operation,
2. the dynamic type of the visitor object representing the operation.

Answer: No. The method that is called by `v.visit(this)` is determined at compile-time.

Reflections on the Visitor Structure

Can we move the implementation of accept higher up the Element hierarchy?

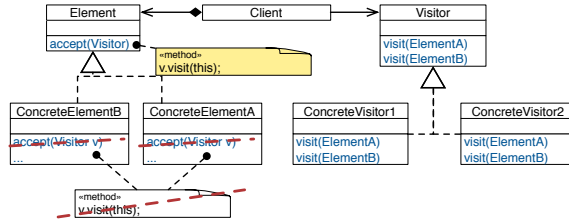

9

Some Terminology

Double Dispatch

Dispatching an operation based on the dynamic type of two objects is called double dispatch.

Double dispatch is not supported in mainstream OO languages, e.g., Java.

10

Double-Dispatch

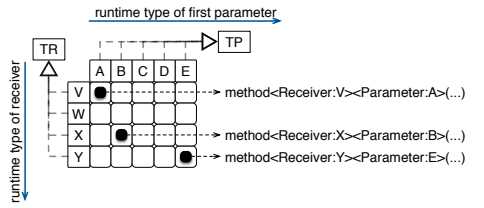

Method call in an object-oriented program: receiver.message(param1,param2,...)
 The function that is called depends on the run-time type of the receiver. Double dispatch is a natural extension of this idea, the function that is called is determined by the run-time type of the receiver and the run-time type of the first parameter. It is easy to model this behavior (double-dispatch) with a two-dimensional table of pointers to functions:

- the runtime type of the receiving object is used to determine a row in the table, and
- the runtime type of the first parameter is used to determine a column in the table.

Case-Study: Calculating Shape Intersection

Task: Implement an intersect operation that calculates whether two given shapes intersect.

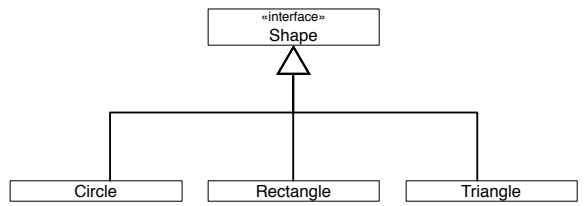

Case-Study: Calculating Shape Intersection

Task: Implement an intersect operation that calculates whether two given shapes intersect.

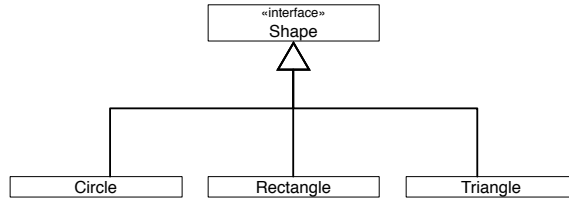

```
Shape t = new Triangle(...);
Shape r = new Rectangle(...);
if (t.intersect(r)) {...}
```

13

For the proposed solution, **the implementation of intersect depends on the dynamic type of both the receiver (t) and parameter (r) shapes.**

Hence, we need to simulate double dispatch in Java.

Case-Study: Calculating Shape Intersection

Simulating Double Dispatch

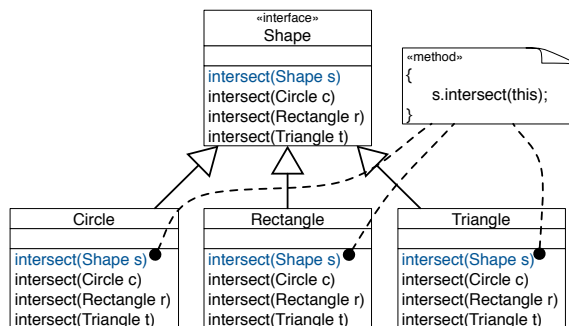

14

Do you see how this design simulates double dispatch?

Case-Study: Calculating Shape Intersection

Simulating Double Dispatch

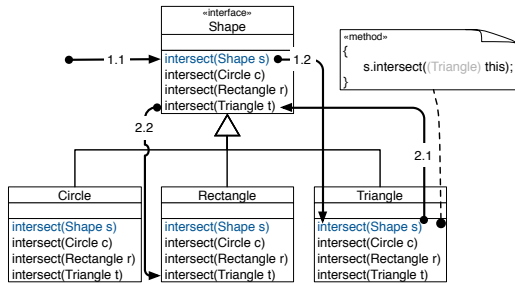

```
Shape t = new Triangle(_);
Shape r = new Rectangle(_);
if (t.intersect(r)) {...}
```

15

External call `t.intersect(r)` is dispatched based on dynamic type of `t`.
Internal call `s.intersect(this)` is dispatched based on dynamic type of `r`.

How do you judge this design?

Assessment:

- The given design forces every shape class to implement its intersection with every other shape. Adding new shapes means implementing new methods in every other shape.
- The double dispatch approach compromises the semantic-hierarchy concept.
- This results in an inheritance tree where each derivative is aware of all other derivatives.

Case-Study: Shape Intersection Using Visitor

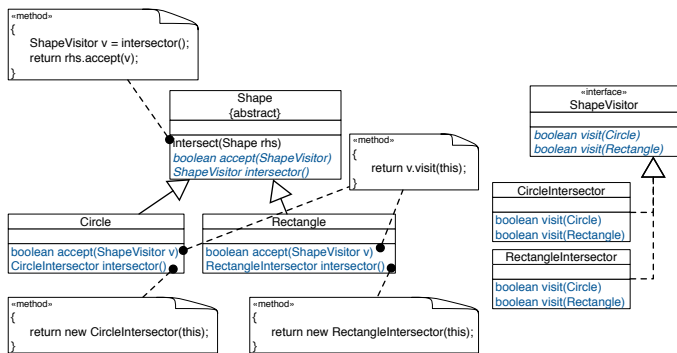

16

The Visitor Pattern can be used to **eliminate the cross-reference in each shape derivative to each other shape derivative**. The key idea is to move the intersect functionality to visitors and to implement one intersection visitor (e.g., `CircleIntersection` or `RectangleIntersection`) per Shape type.

Case-Study: Shape Intersection Using Visitor

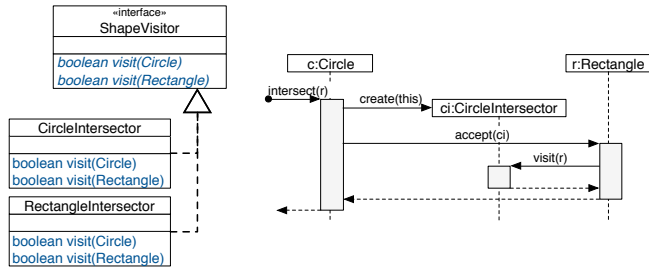

```
Shape c = new Circle(_);  
Shape r = new Rectangle(_);  
if (c.intersect(r)) {...}
```

17

Advantages of the Visitor Design Pattern

- **New operations are easy to add** without changing element classes (add a new concrete visitor). Different concrete elements do not have to implement their part of a particular algorithm.
- Related behavior focused in a single concrete visitor.
- **Visiting across hierarchies:** Visited classes are not forced to share a common base class.
- **Accumulating state:** Visitors can accumulate state as they visit each element, thus, encapsulating the algorithm and all its data.

18

Issues of the Visitor-Based Design

What happens if we want to add a new element?

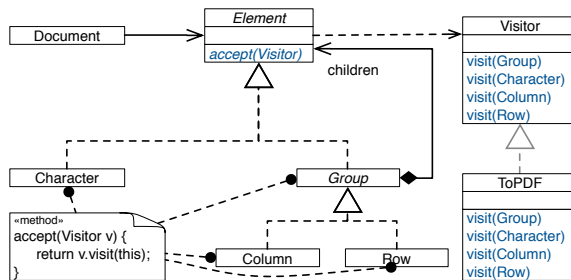

19

Description:

- Visitor visits all elements of a document.
- ToPDF converts documents to PDF.
- Various other concrete visitors may be implemented:
spell checking, grammar checking, text analysis, speaking text service, ...

Issues of the Visitor-Based Design

E.g., adding `Chart` (adding Elements)

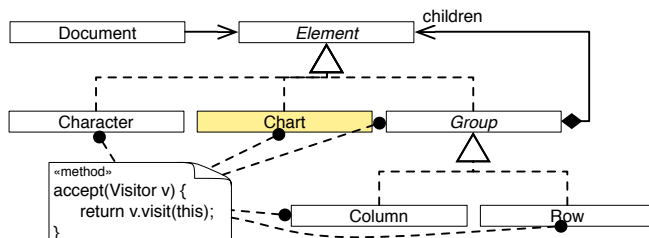

20

Problem: Since Visitor has no method for Chart, its objects won't be processed by any visitor. Our design is not closed against this kind of change.

Issues of the Visitor-Based Design

E.g., adding **Chart** and updating **Visitor**

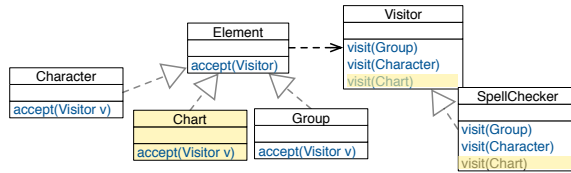

21

Issues:

- We have to change all visitors for every new element.
- Many visitors will have empty methods to comply to the interface.
- Sometimes data structures are extended, but it's optional to process extensions.
E.g., it doesn't make sense to spell-check charts, i.e., `SpellChecker.visit(Chart)` will be empty.

Issues of the Visitor-Based Design

E.g., adding **Chart** and keeping **Visitor** unchanged

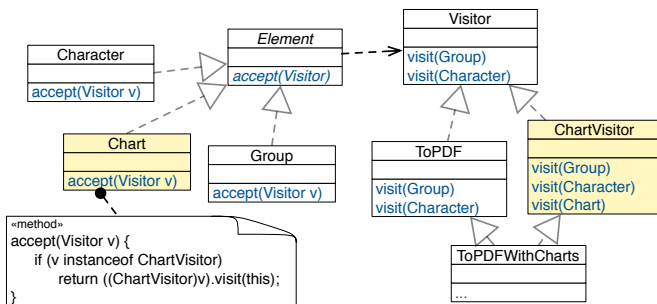

22

Ask yourself: which design principles are violated?

Issues of the Visitor-Based Design

E.g., adding **Chart** and keeping **Visitor** unchanged

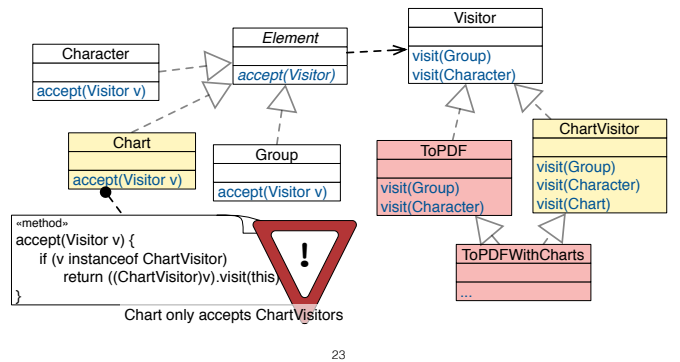

Try to avoid such visitors as these implementations are extremely fragile; they are maintenance nightmares when more elements are added.

Issues of the Visitor-Based Design

Partial Visiting Is Not Supported

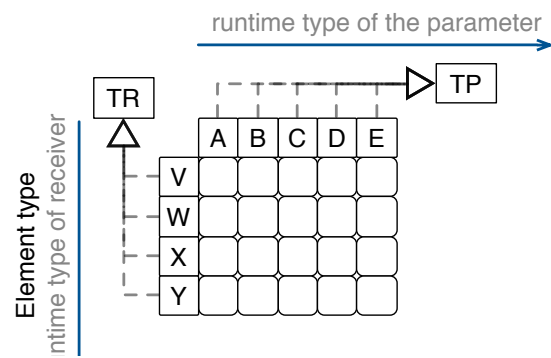

Partial visiting is not supported!

To provide a common abstract Visitor interface to Element, every derivative of Element need to be addressed by every derivative of Visitor; even if this might not make sense or is not needed. We have seen this for `SpellChecker.visit(Char)`

Takeaway

- Visitor brings functional-style decomposition to OO designs.
- **Use Visitor for stable element hierarchies.**
Visitor works well in data hierarchies where new elements are never or at least not very often added.
- **Do not use it, if new elements are a likely change.**
- Visitor only makes sense if we have to add new operations often! In this case Visitor closes our design against these changes.

25

Solving the Expression Problem in Scala

The base trait.

```
trait Expressions {  
  type Expression <: TExpression  
  trait TExpression {  
    def eval: Double  
  }  
  trait Constant extends TExpression {  
    val v: Double  
    def eval = v  
  }  
}
```

Resembles the solution that we have studied as part of the implementation of the SmartHome Scenario.

Without Visitors

26

Recommended reading:

Matthias Zenger and Martin Odersky, Independently Extensible Solutions to the Expression Problem, FOOL 2005

To make it possible to extend the Expression trait (i.e., to enable an independently developed extension to contribute functionality to Expressions) we have to abstract over the concrete type of Expression.

Solving the Expression Problem in Scala

Adding a new data-type.

```
trait AddExpressions extends Expressions {  
  trait Add extends TExpression {  
    val l: Expression  
    val r: Expression  
    def eval = l.eval + r.eval  
  }  
}
```

Resembles the solution that we have studied as part of the implementation of the SmartHome Scenario.

27

Without Visitors

Solving the Expression Problem in Scala

Adding new functionality.

```
trait PrefixNotationForExpressions extends AddExpressions {  
  type Expression <: TExpression  
  trait TExpression extends super.TExpression {  
    def prefixNotation: String  
  }  
  
  trait Constant extends super.Constant with TExpression {  
    def prefixNotation = v.toString  
  }  
  
  trait Add extends super.Add with TExpression {  
    def prefixNotation = "+" + l.prefixNotation + r.prefixNotation  
  }  
}
```

Resembles the solution that we have studied as part of the implementation of the SmartHome Scenario.

28

Without Visitors

Solving the Expression Problem in Scala

Bringing everything together.

```
object ExpressionsFramework
  extends PrefixNotationForExpressions
  with PostfixNotationForExpressions {

  type Expression = TExpression
  trait TExpression
    extends super[PrefixNotationForExpressions].TExpression
    with super[PostfixNotationForExpressions].TExpression

  case class Constant(v: Double)
    extends super[PrefixNotationForExpressions].Constant
    with super[PostfixNotationForExpressions].Constant
    with Expression

  case class Add(val l: Expression, val r: Expression)
    extends super[PrefixNotationForExpressions].Add
    with super[PostfixNotationForExpressions].Add
    with Expression
}
```

Resembles the solution that we have studied as part of the implementation of the SmartHome Scenario.

Without Visitors

29

Assessment:

- The solution is open w.r.t. to directly adding new functionality to expressions and w.r.t. adding new data-types that inherit from Expression.
- It is easy to add support for new data-types (e.g., Add).
- It is possible to add new functionality (in a type-safe way), but this requires a deep-mixin composition.
- The solution is subject to the fragile base-class problem.

Solving the Expression Problem in Scala

The base trait.

```
trait Expressions {

  trait Expression { def accept[T](visitor: Visitor[T]): T }

  class Constant(val v: Double) extends Expression {
    def accept[T](visitor: Visitor[T]): T = visitor.visitConstant(v)
  }

  type Visitor[T] <: TVisitor[T]
  trait TVisitor[T] {
    def visitConstant(v: Double): T
  }

  trait EvalVisitor extends TVisitor[Double] {
    def visitConstant(v: Double): Double = v
  }
}
```

With Visitors

30

Recommended reading:

Matthias Zenger and Martin Odersky, Independently Extensible Solutions to the Expression Problem, FOOL 2005

This solution does not support adding methods/functionality to an expression at runtime or by a third-party extension, i.e., an independently developed extension of the Expressions trait cannot contribute to the `Expression` trait.

Solving the Expression Problem in Scala

Adding a new data-type.

```
trait AddExpressions extends Expressions {  
  class Add(val l: Expression,  
            val r: Expression) extends Expression {  
    def accept[T](visitor: Visitor[T]): T = visitor.visitAdd(l, r)  
  }  
  
  type Visitor[T] <: TVisitor[T]  
  trait TVisitor[T] extends super.TVisitor[T] {  
    def visitAdd(l: Expression, r: Expression): T  
  }  
  
  trait EvalVisitor extends super.EvalVisitor with TVisitor[Double] {  
    this: Visitor[Double] =>  
    def visitAdd(l: Expression, r: Expression): Double =  
      l.accept(this) + r.accept(this)  
  }  
}
```

31

With Visitors

Solving the Expression Problem in Scala

Bringing everything together.

```
trait ExtendedExpressions extends AddExpressions with MultExpressions {  
  type Visitor[T] = TVisitor[T]  
  trait TVisitor[T]  
    extends super[AddExpressions].TVisitor[T]  
    with super[MultExpressions].TVisitor[T]  
  
  object EvalVisitor  
    extends super[AddExpressions].EvalVisitor  
    with super[MultExpressions].EvalVisitor  
    with TVisitor[Double] {  
    this: Visitor[Double] =>  
  }  
}
```

32

With Visitors

By making the type visitor concrete (type `Visitor[T] = TVisitor[T]`) the data-type hierarchy is now fixed; extension is only possible w.r.t. new functionality.

Solving the Expression Problem in Scala

Adding new functionality.

```
trait PrefixNotationForExpressions extends ExtendedExpressions {  
  object PrefixNotationVisitor extends super.TVisitor[String] {  
    this: Visitor[String] =>  
  
    def visitConstant(v: Double): String = v.toString+" "  
  
    def visitAdd(l: Expression, r: Expression): String =  
      "+ "+l.accept(this) + r.accept(this)  
  
    def visitMult(l: Expression, r: Expression): String =  
      "* "+l.accept(this) + r.accept(this)  
  
  }  
}
```

33

With Visitors

Assessment:

- The solution is open w.r.t. to adding new functionality to expressions by means of a visitor and w.r.t. adding new data-types that inherit from Expression.
- It is easy to add new functionality (e.g., PrefixNotationForExpressions).
- **It is possible to add new data-types (in a type-safe way), but this requires a deep-mixin composition.**
- The solution is subject to the fragile base-class problem.